

Features

- 20A switching capability
- Single coil and double coil are all available
- We can provide the product with ambient temperature is 105°C
- The contact can withstand 750A 10ms short-circuit impulse current
- The contact on and off can be controlled by the hand control switch
- Product in accordance to IEC60335-1 available
- UL insulation system: Class F
- Environmental friendly product (RoHS compliant)
- Outline Dimensions: (28.8×12.5×16.0) mm
- Main application: Smart home、Lighting control



TV-8  **US**

CHARACTERISTICS

Specifications	Item		
Contact Data	Contact arrangement		1A、1B、1C
	Contact resistance(initial)		20mΩ(6VDC 1A)
	Contact material		AgSnO ₂
Rated value	Rated load(Resistance load)		20A 250VAC 16A 250VAC
	Max.switching voltage		277VAC
	Max.switching current		20A
	Max.switching capacity		5000VA
	Min.allowing load		5VDC 100mA
Electrical performance	Insulation resistance(initial)		1000MΩ(500VDC)
	Dielectric strength (initial)	Between open contacts	1000VAC,1min
		Between coil&contacts	4000VAC,1min
	Operate time		≤15ms
	Release time		≤15ms
Mechanical performance	Shock resistance	Functional	98m/s ² (10G)
		Destructive	980m/s ² (100G)
	Vibration resistance		10Hz~55Hz 1.5mm min
Endurance	Mechanical		1×10 ⁶ ops
	Electrical	20A 250VAC	5×10 ⁴ ops(ON/OFF=1s/9s)
		16A 250VAC	1×10 ⁵ ops(ON/OFF=1s/9s)
		1/2HP 120VAC(motor)	8×10 ⁴ ops(ON/OFF=1s/9s)
		1200W 120VAC(osram lamp)	7×10 ⁴ ops(ON/OFF=1s/9s)
		1200W 120VAC(LED lamp)	2×10 ⁴ ops(ON/OFF=1s/9s)
Operate condition	Ambient temperature		-40°C~85°C
	Humidity		5% to 90%
Termination			PCB
Unit weight			Approx.15g
Construction			Plastic sealed,Flux proofed

COIL DATA(23°C)

Single coil latching

Nominal Voltage	Pick-up Voltage VDC	Drop-out Voltage VDC	Rated Current (±10%)	Coil Resistance (±10%)	Nominal Power	Max Voltage
DC 5V	≤3.75	≤3.75	100mA	50Ω	500mW	150%Nominal Voltage
DC 6V	≤4.50	≤4.50	83.3mA	72Ω		
DC 9V	≤6.75	≤6.75	55.6mA	162Ω		
DC 12V	≤9.00	≤9.00	41.7mA	288Ω		
DC 24V	≤18.00	≤18.00	20.8mA	1152Ω		
DC 36V	≤27.00	≤27.00	13.9mA	2592Ω		
DC 48V	≤36.00	≤36.00	10.4mA	4608Ω		

Double coils latching

Nominal Voltage	Pick-up Voltage VDC	Drop-out Voltage VDC	Rated Current(±10%)	Coil Resistance (±10%)	Nominal Power	Max Voltage
DC 5V	≤3.75	≤3.75	200/200mA	25/25Ω	1000mW	150%Nominal Voltage
DC 6V	≤4.50	≤4.50	167/167mA	36/36Ω		
DC 9V	≤6.75	≤6.75	111/111mA	81/81Ω		
DC 12V	≤9.00	≤9.00	83.3/83.3mA	144/144Ω		
DC 24V	≤18.00	≤18.00	41.7/41.7mA	576/576Ω		
DC 36V	≤27.00	≤27.00	27.8/27.8mA	1296/1296Ω		
DC 48V	≤36.00	≤36.00	20.8/20.8mA	2304/2304Ω		

ORDERING INFORMATION

W15L -1A 1 S T M -L1 R -XXX DC12V

① Type

② Contact arrangement: 1A=1open contacts、1B=1close contacts、1C=1switched contacts

③ PCB mounting: 1=type 1、2=type 2、3=type 3
5=type 5、6=type 6

④ Construction: Nil=Flux proofed, S=Plastic sealed

⑤ Contact material: T=AgSnO₂

⑥ Control type: Nil=No hand control switch、
M=with hand control switch(No Plastic sealed and 1C type)

⑦ Coil type: L1=coil latching、L2=coils latching

⑧ Operation polarity: Nil=standard polarity R=reversed polarity

⑨ Customer special code: numbers or letters denote customer's requirements

⑩ Coil specification: DC5/6/9/12/24/36/48V

OUTLINE DIMENSIONS, WIRING DIAGRAM AND PC BOARD LAYOUT (Unit: mm)

1A1/1B1 Outline Dimensions
(single coil latching)

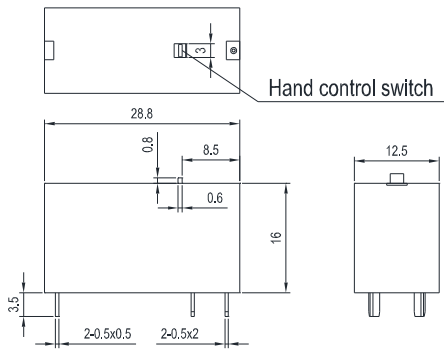

Wiring Diagram
(Bottom view)

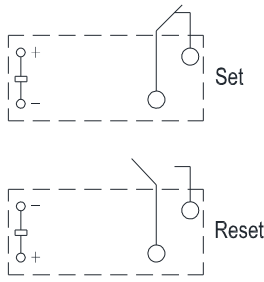

PCB Layout
(Bottom view)

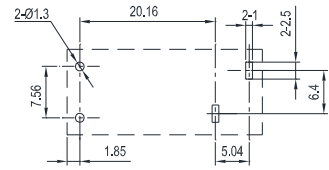

1A1/1B1 Outline Dimensions
(double coils latching)

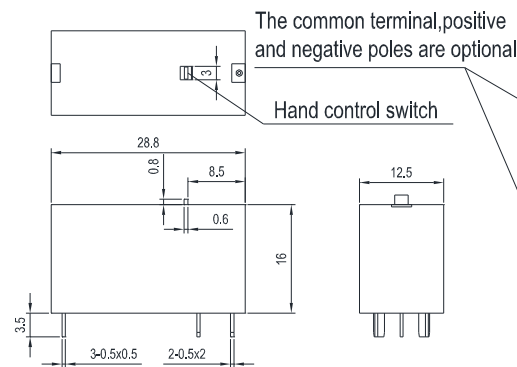

Wiring Diagram
(Bottom view)

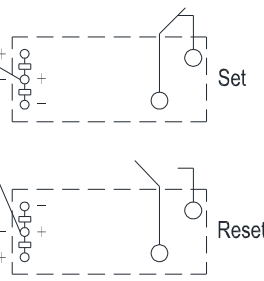

PCB Layout
(Bottom view)

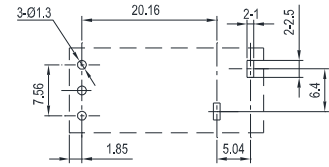

1A2/1B2 Outline Dimensions
(single coil latching)

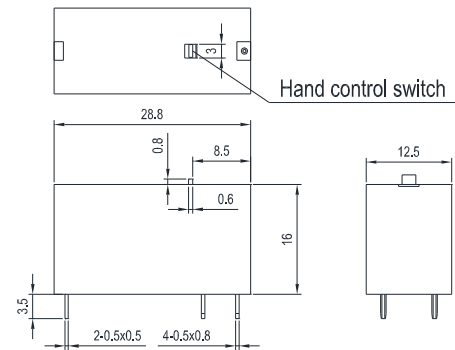

Wiring Diagram
(Bottom view)

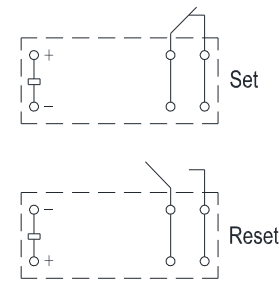

PCB Layout
(Bottom view)

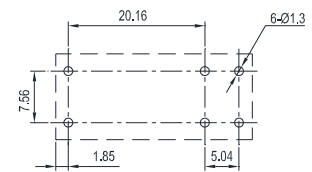

1A2/1B2 Outline Dimensions
(double coils latching)

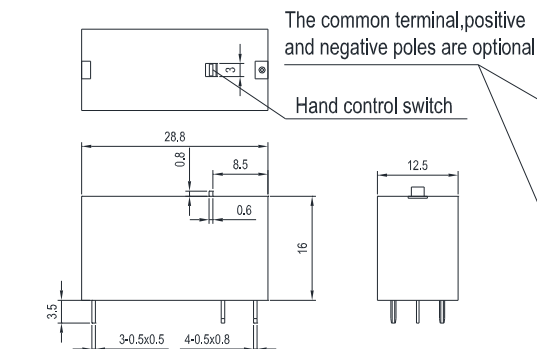

Wiring Diagram
(Bottom view)

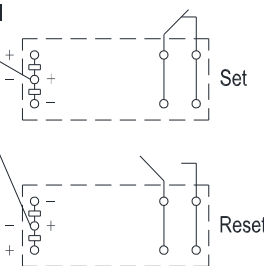

PCB Layout
(Bottom view)

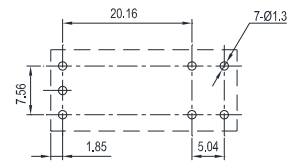

OUTLINE DIMENSIONS, WIRING DIAGRAM AND PC BOARD LAYOUT (Unit: mm)

1A3/1B3 Outline Dimensions
(single coil latching)

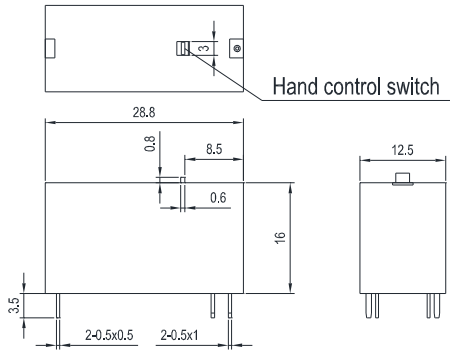

Wiring Diagram
(Bottom view)

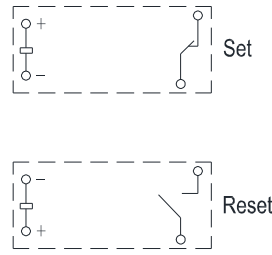

PCB Layout
(Bottom view)

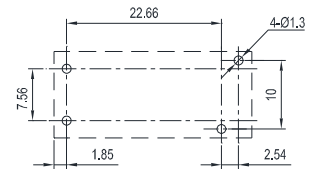

1A3/1B3 Outline Dimensions
(double coils latching)

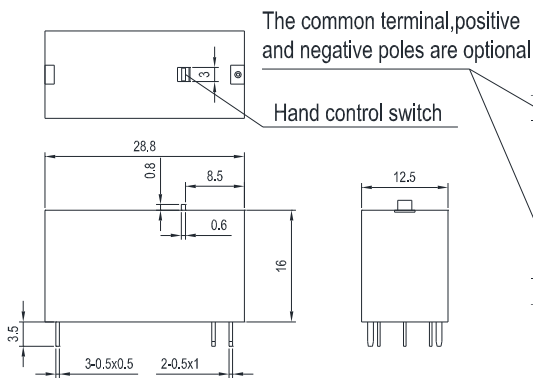

Wiring Diagram
(Bottom view)

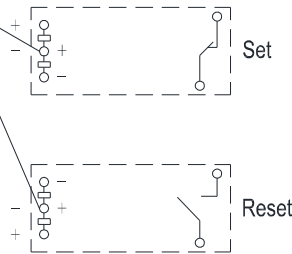

PCB Layout
(Bottom view)

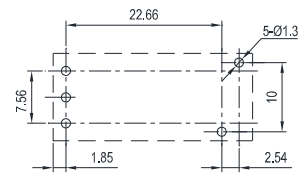

1A5/1B5 Outline Dimensions
(single coil latching)

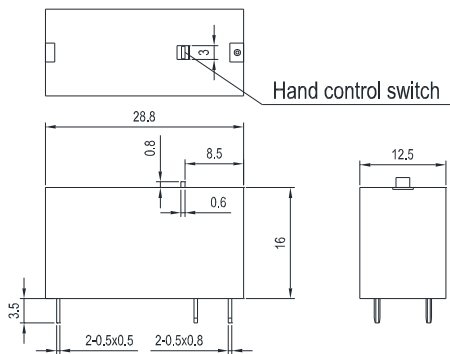

Wiring Diagram
(Bottom view)

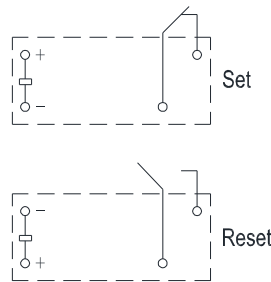

PCB Layout
(Bottom view)

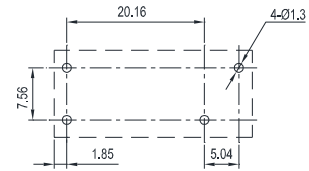

1A5/1B5 Outline Dimensions
(double coils latching)

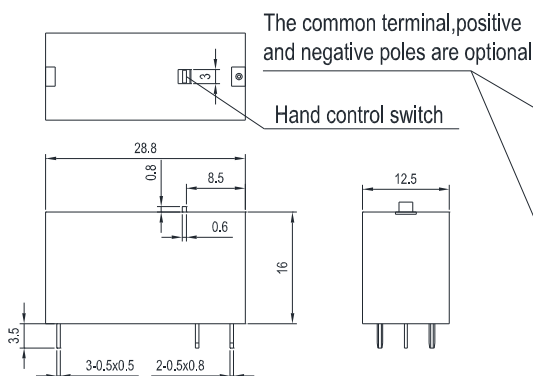

Wiring Diagram
(Bottom view)

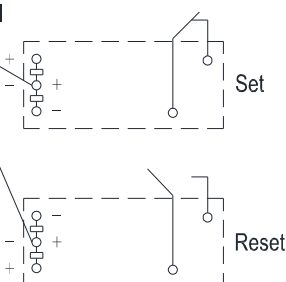

PCB Layout
(Bottom view)

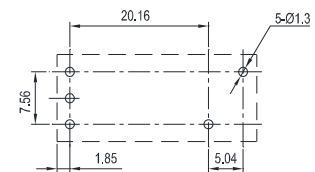

OUTLINE DIMENSIONS, WIRING DIAGRAM AND PC BOARD LAYOUT (Unit: mm)

1A6/1B6 Outline Dimensions
(single coil latching)

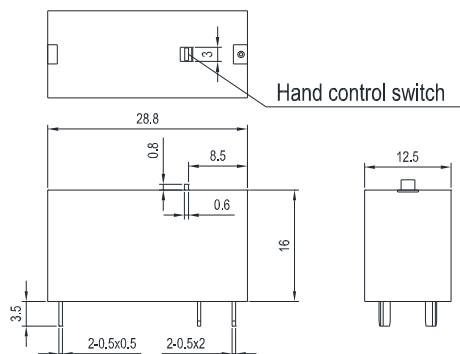

Wiring Diagram
(Bottom view)

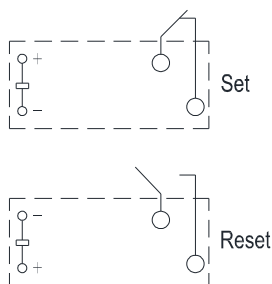

PCB Layout
(Bottom view)

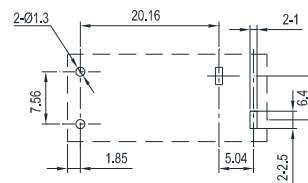

1A6/1B6 Outline Dimensions
(double coils latching)

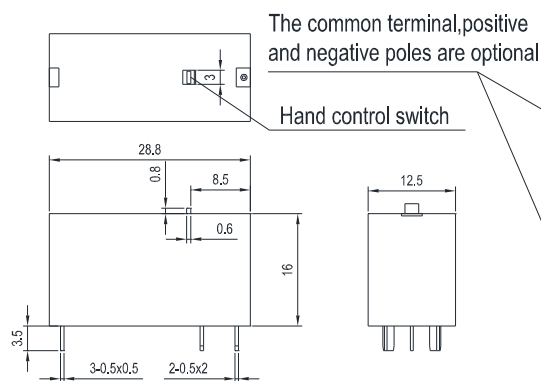

Wiring Diagram
(Bottom view)

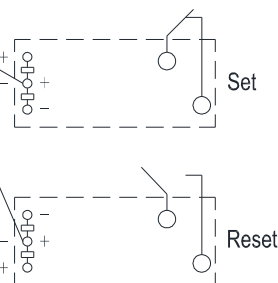

PCB Layout
(Bottom view)

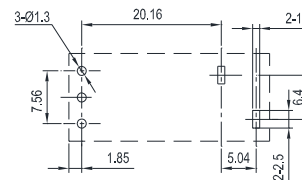

1C2 Outline Dimensions
(single coil latching)

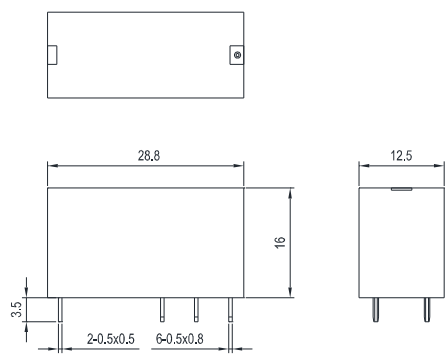

Wiring Diagram
(Bottom view)

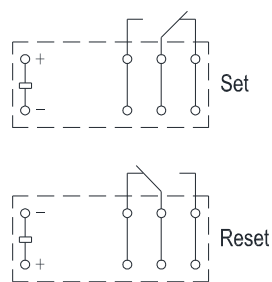

PCB Layout
(Bottom view)

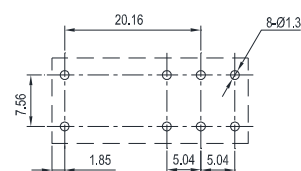

1C2 Outline Dimensions
(double coils latching)

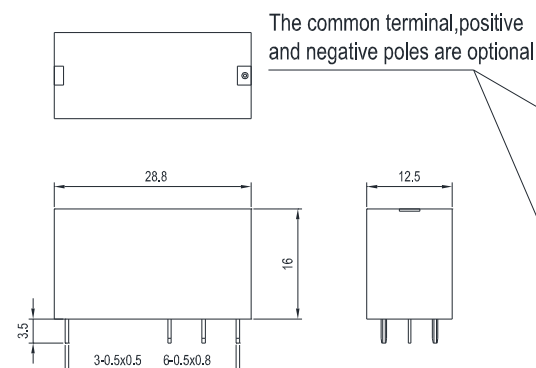

Wiring Diagram
(Bottom view)

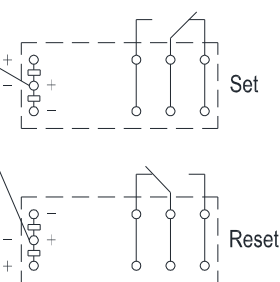

PCB Layout
(Bottom view)

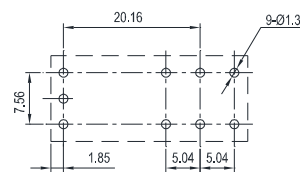

OUTLINE DIMENSIONS, WIRING DIAGRAM AND PC BOARD LAYOUT (Unit: mm)

1C5 Outline Dimensions
(single coil latching)

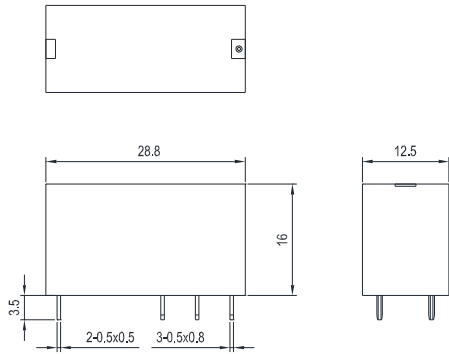

Wiring Diagram
(Bottom view)

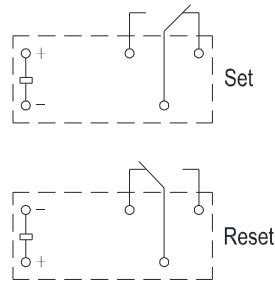

PCB Layout
(Bottom view)

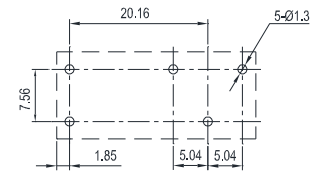

1C5 Outline Dimensions
(double coils latching)

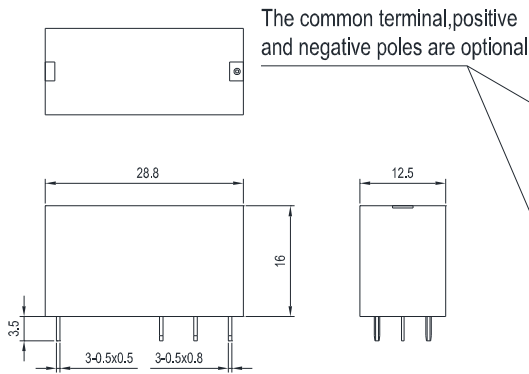

Wiring Diagram
(Bottom view)

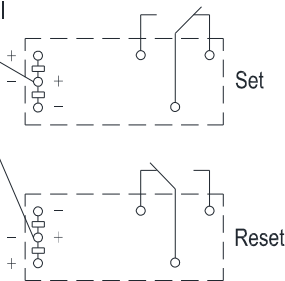

PCB Layout
(Bottom view)

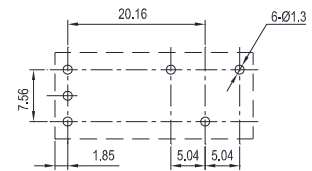

Notes:(1) In case of no tolerance shown in outline dimension:outline dimension \leq 1mm,tolerance should be \pm 0.2mm;outline dimension $>$ 1mm and $<$ 5mm,tolerance should be \pm 0.3mm;outline dimension \geq 5mm,tolerance should be \pm 0.5mm.

(2) The tolerance without indicating for PCB layout is always \pm 0.1mm.

SAFETY APPROVAL RATINGS

Approval	File No.	Contact arrangement	Contact material	Approved ratings		
UL/C-UL	E475405	1A、1C(NO)	AgSnO ₂	16A	250/125VAC	85/105°C
		1B、1C(NC)		20A	250/125VAC	85°C
				1/2HP	120VAC	85°C
		1200W		120VAC(osram lamp、LED lamp)	85/105°C	
				10A	250VAC(PF=0.4)	85°C
				TV-8	250/125VAC	85°C
TUV	R 50401990	1A(NO) 1B(NC)	AgSnO ₂	16A	250/125VAC	85°C
				20A	250/125VAC	85°C
CQC	CQC18002187939	1A(NO)	AgSnO ₂	20A	250/125VAC	85°C
		1B(NC)		16A	250/125VAC	85°C
				16A	250/125VAC	85°C

PERFORMANCE CURVES

MAXIMUM SWITCHING POWER

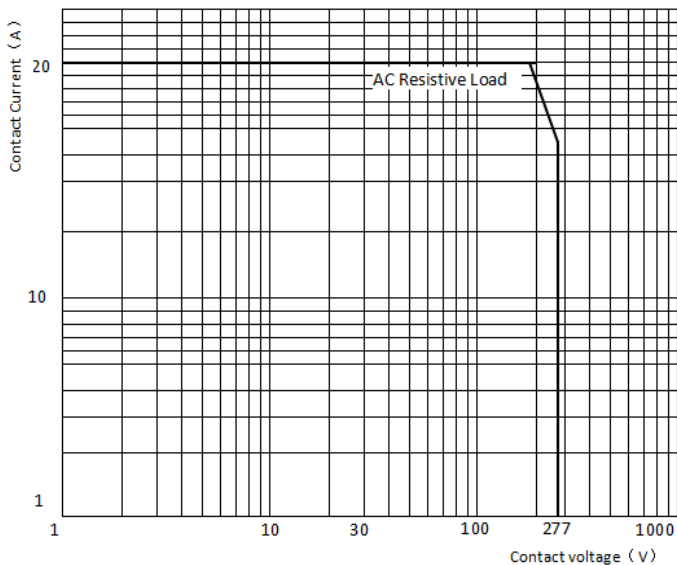

ENDURANCE CURVE

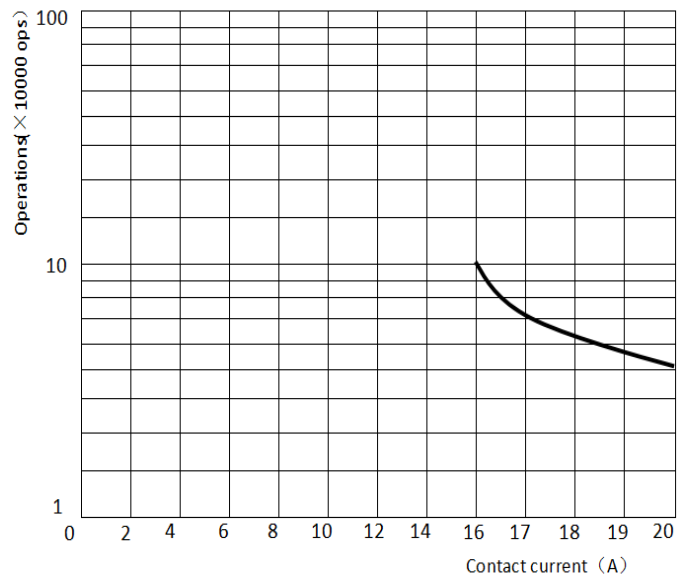

■ NOTICE

- ① If the relay needs to be cleaned or used in bad environment(e.g:dust or organic gas),we recommend plastic sealed type.
- ② The specification is for reference only,specifications subject to change without notice.
- ③ With the consideration of shock risen from transit and relay mounting,relay's initial state might be changed ,please impose pulse voltage to reset the relay before using(rated coil voltage,impulse width \geq 5 times operation time.